

# Airworthiness Directive Schedule

## Aeroplanes

### Beechcraft 58 and 95 Series (Baron)

29 August 2013

---

- Notes:** 1. This AD schedule is applicable to Beechcraft aircraft manufactured under Federal Aviation Administration (FAA) Type Certificates:

Aircraft model:	FAA Type Certificate Number:
58	3A16
95-A55	3A16
95-B55	3A16
95-C55	3A16
58P	A23CE

2. The FAA is the National Airworthiness Authority (NAA) responsible for the issue of State of Design Airworthiness Directives (ADs) for these aircraft.

State of Design ADs can be obtained directly from the FAA website at: [Dynamic Regulatory System \(faa.gov\)](http://www.faa.gov/dynamic_regulatory_system/)

3. The date above indicates the amendment date of this schedule.  
4. New or amended ADs are shown with an asterisk \*
- 

## Contents

DCA/B55/1	Cancelled, Purpose fulfilled.....	3
DCA/B55/3	Cancelled, Purpose fulfilled.....	3
DCA/B55/5	Fuel System Operation - Placards - Modification .....	3
DCA/B55/7	Cancelled, Purpose fulfilled.....	3
DCA/B55/9	Control Wheel Adaptor - Replacement.....	3
DCA/B55/11	Fuel System Minimum Fuel for Take-off - Decals - Modification .....	3
DCA/B55/12A	Elevator Trim Tab - Modification and Inspection .....	3
DCA/B55/13	Cancelled: Purpose fulfilled.....	3
DCA/B55/14	Seat Belts - Modification .....	4
DCA/B55/15	Control Wheel Adaptor - Inspection .....	4
DCA/B55/16A	Flexible Fuel Tanks - Inspection .....	4
DCA/B55/17	Flight Controls - Inspection .....	4
DCA/B55/18A	Rear Fuselage - Inspection.....	5
DCA/B55/19	Elevator Control Rods - Inspection.....	5
DCA/B55/20	Nose Baggage Door Latching - Modification.....	5
DCA/B55/21	Emergency Exits - Placard And Modification .....	5
DCA/B55/22	Seat Attachments - Modification .....	6
DCA/B55/23	Seat Recline Actuator - Modification .....	6
DCA/B55/24	Seat Installations - Inspection And Modification.....	6
DCA/B55/25	Elevator Control Fittings - Inspection .....	6
DCA/B55/26	Wing Forward Spar Carry-Through Structure - Inspection.....	7
DCA/B55/27	Cancelled – DCA/B55/45 refers .....	7
DCA/B55/28	Engine Mount - Inspection .....	7
DCA/B55/29	Elevator Trim Tab Actuator - Colour Coding .....	8
DCA/B55/30	Fuselage - Inspection and Modification.....	8
DCA/B55/31	Interior Door Handles - Inspection.....	8
DCA/B55/32	Severe Icing Conditions - Flight Manual Revision.....	9
DCA/B55/33	Cancelled – Purpose Fulfilled .....	10
DCA/B55/34	Flight Controls – Inspection for Interference .....	10

DCA/B55/35	Elevator Skin Assemblies - Replacement .....	11
DCA/B55/36	Rudder Interconnect Tube - Inspection .....	11
DCA/B55/37A	Fuselage Assembly - Inspection .....	12
DCA/B55/38	Rudder Control System - Inspection .....	12
DCA/B55/39	Flap Flex Shafts - Inspection.....	13
DCA/B55/40	Electroluminescent Panel Retaining Screw – Inspection .....	13
DCA/B55/41	Propeller Unfeathering Accumulators – Inspection and Replacement .....	14
DCA/B55/42	MLG Retract Mechanism – Modification and Lubrication.....	14
DCA/B55/43	Airframe Structure – Life Limitation & AFM Amendment.....	15
DCA/B55/44	Circuit Breaker Toggle Switches – Replacement.....	15
DCA/B55/45	Shoulder Harness Guide Retaining Washer – Inspection and Replacement .....	16
DCA/B55/46A	Elevator Control System – Inspection and Replacement .....	17
DCA/B55/47	Airspeed Indicator Markings – Inspection and Rework .....	18
DCA/B55/48	Fuel Hose Clamps – Inspection and Replacement .....	18
2012-21-05	Strobe System Wiring – Replacement .....	19
* 2013-16-01	Elevator Balance Weights – Inspection.....	19

<b>DCA/B55/1</b>	<b>Cancelled, Purpose fulfilled</b>
<b>DCA/B55/3</b>	<b>Cancelled, Purpose fulfilled</b>
<b>DCA/B55/5</b>	<b>Fuel System Operation - Placards - Modification</b>
<b>Applicability:</b>	All model 95-B55 aircraft
<b>Requirement:</b>	Beech SI 0005-010
<b>Compliance:</b>	Within the next 10 hours TIS
<b>Effective Date:</b>	31 March 1969
<b>DCA/B55/7</b>	<b>Cancelled, Purpose fulfilled</b>
<b>DCA/B55/9</b>	<b>Control Wheel Adaptor - Replacement</b>
<b>Applicability:</b>	Model 95-B55 aircraft, S/N TC-502 through TC-1020 if control wheel P/N 60-524080 is incorporated
<b>Requirement:</b>	Beech SI 0254-156 (FAA AD 71-24-10 refers)
<b>Compliance:</b>	Within the next 50 hours TIS
<b>Effective Date:</b>	30 June 1971
<b>DCA/B55/11</b>	<b>Fuel System Minimum Fuel for Take-off - Decals - Modification</b>
<b>Applicability:</b>	Model 95-55, 95-A55, 95-B55 and 95-B55A aircraft, S/N TC-1 through TC-1382
<b>Requirement:</b>	Beech SI 0492-281 (FAA AD 72-11-2 refers)
<b>Compliance:</b>	Next periodic inspection
<b>Effective Date:</b>	31 December 1972
<b>DCA/B55/12A</b>	<b>Elevator Trim Tab - Modification and Inspection</b>
<b>Applicability:</b>	Model 95-B55 aircraft, S/N TC-1 through TC-1143 except TC-350
<b>Requirement:</b>	Beech SI 0610-152 Rev 11. (FAA AD 75-16-10 refers)
<b>Compliance:</b>	Part I of the SI - Modification - Within the next 100 hours TIS. Part II of SI - Inspection - Within the next 25 hours TIS and thereafter at intervals not exceeding 100 hours TIS until modified in accordance with Part II or Part III of SI. Part II or Part III of the SI - Modification - By 31 October 1975
<b>Effective Date:</b>	18 July 1975
<b>DCA/B55/13</b>	<b>Cancelled: Purpose fulfilled</b>

**DCA/B55/14      Seat Belts - Modification****Applicability:** Model 58 aircraft, S/N TH519 through TH732**Requirement:** Beech SI 0850-313  
(FAA AD 76-22-02 refers)**Compliance:** Within next 100 hours TIS**Effective Date:** 14 December 1976**DCA/B55/15      Control Wheel Adaptor - Inspection****Applicability:** All model 58 series aircraft  
All model 95-A55 and 95-B55 series aircraft.**Requirement:** Inspect per Beechcraft SI 0254-156 revision IV.**Compliance:** Before further flight, except that aircraft may be flown to base for accomplishment of inspection.**Effective Date:** 11 April 1978**DCA/B55/16A      Flexible Fuel Tanks - Inspection****Applicability:** Model 58 series aircraft, S/N TH-1 through TH-384 Models 95-A55 and 95-B55 S/N TC-380 through TC-1607

Model 95-C55 aircraft, S/N TE-1 through TE-942.

Also any other Model 58 and 95-55 Series aircraft equipped with Goodyear BTC-39 Series fuel tanks.

**Requirement:** Accomplish the following:

1. Establish type of fuel tank fitted per Beech SI 0895.
2. If Goodyear BTC-39 tanks found fitted, continue with inspection procedure per Beech SI 0895.

(Goodyear SB TF-77-1 and FAA AD 78-05-06 refers)

**Compliance:**

1. Within the next 25 hours TIS or 30 days, whichever is the sooner.
2. Within next 100 hours TIS or 6 months, whichever is the sooner, thereafter at intervals not exceeding 12 months.

**Effective Date:** DCA/B55/16 - 12 May 1978  
DCA/B55/16A - 4 April 1980**DCA/B55/17      Flight Controls - Inspection****Applicability:** Model 58 aircraft, S/N TH-343 through TH-779.**Requirement:** Inspect rudder and elevator hinges for installation of correct screws per Beech SI 0629-150 Rev.1.**Compliance:** Within next 100 hours TIS.**Effective Date:** 26 May 1978

**DCA/B55/18A Rear Fuselage - Inspection**

**Applicability:** Models 95-A55 and 95-B55 aircraft, S/N TC-1 through TC-349 and TC-351 through TC-2124.

Model 58 aircraft S/N TH-1 through TH-908

Model 95-C55 aircraft, S/N TE-1 through TE-1124.

**Requirement:** Inspect bulkheads at fwd. and aft horizontal stabiliser stub spar locations for cracks per Beech SI 0990 and repair as necessary.

**Compliance:** Within next 100 hours TIS and thereafter at intervals not exceeding 500 hours TIS, or 12 months whichever is the sooner, until repair or reinforcement per Part II of SI 0990 is embodied.

**Effective Date:** DCA/B55/18 - 16 April 1979  
DCA/B55/18A - 4 April 1980

**DCA/B55/19 Elevator Control Rods - Inspection**

**Applicability:** Models 95-A55, 95-B55 and 95-C55 aircraft, S/N TC-1 through TC-349 and TC-351 through TC-2169 and TE-1 through TE-1138

Model 58 aircraft, S/N TH-1 through TH-958.

**Requirement:** Inspect and apply corrosion protection per Beech SI 1019. Renew rods found defective before further flight.

**Compliance:** Within next 100 hours TIS unless already accomplished.

**Effective Date:** 4 April 1980

**DCA/B55/20 Nose Baggage Door Latching - Modification**

**Applicability:** Models 95-A55, 95-B55 and 95-C55 aircraft, S/N TC-1 through TC-349, TC-351 through TC-1392, TC-1397 through TC-1401, TC-1403 through TC-2384, S/N TE-1 through TE-49 and TE-51 through TE-1189

Models 58 and 58P aircraft, S/N TH-1 through TH-1246 and TJ-3 through TJ-370.

**Requirement:** To preclude possibility of nose baggage door latching becoming unsafe in flight, modify per Beechcraft SI 1195.

**Compliance:** Within next 100 hours TIS.

**Effective Date:** 8 October 1982

**DCA/B55/21 Emergency Exits - Placard And Modification**

**Applicability:** Model 58 aircraft, S/N TH-1 through TH-1079

Models 95-A55, 95-B55 and 95-C55 aircraft, S/N TC-1 through TC-2354 and TE-1 through TE-1880 as respectively detailed in Beechcraft SI 1241.

**Requirement:** Install placards and modify opening window latches per Beechcraft SI 1241.

**Compliance:** Within next 100 hours TIS unless already accomplished.

**Effective Date:** 20 April 1984

**DCA/B55/22      Seat Attachments - Modification**

**Applicability:** Models 58P and 58PA aircraft, S/N TJ-3 through TJ-435 and TJ-437 through TJ-443.  
**Requirement:** Modify fifth and sixth seat attachment brackets per Beechcraft mandatory SB 2022.  
**Compliance:** Within next 50 hours TIS.  
**Effective Date:** 10 May 1985

**DCA/B55/23      Seat Recline Actuator - Modification**

**Applicability:** Model 95-B55 aircraft, S/N TC-2340, TC-2355 through TC-2456  
 Models 58 and 58A aircraft, S/N TH-1027, TH-1062, TH-1067, TH-1080 through TH-1507  
 Models 58P and 58PA aircraft, S/N TJ-210, TJ-235 through TJ-497 fitted with optional hydrolock seat recline actuators on co-pilot and third and fourth passenger seats. (Seats immediately behind pilot and co-pilot).  
**Requirement:** To prevent armrest from contacting seat recline actuator handle and inadvertently releasing seat back locking, modify per Beechcraft SB 2175 Rev.1.  
 (FAA AD 87-18-06 refers)  
**Compliance:** Within next 100 hours TIS.  
**Effective Date:** 19 February 1988

**DCA/B55/24      Seat Installations - Inspection And Modification**

**Applicability:** Models 95-B55 and 95-B55A aircraft, S/N TC-1918 through TC-2456  
 Models 58 and 58A aircraft, S/N TH-579 through TH-1395  
 Models 58P and 58PA aircraft, S/N TJ-12 through TJ-443.  
**Requirement:** Inspect and rework/modify per Beechcraft SB 2010 Rev.1, Parts I and II (as applicable).  
 (FAA AD 88-21-02 refers)  
**Compliance:** Within next 100 hours TIS.  
**Effective Date:** 10 March 1989

**DCA/B55/25      Elevator Control Fittings - Inspection**

**Applicability:** Models 95-55 and 95-B55 aircraft, S/N TC-1 through TC-1287 and any other 95 series aircraft with a replacement magnesium control fitting.  
**Requirement:** To prevent failure, accomplish the following per Beechcraft SB 2242 revision 1:  
 1. Establish control fitting material.  
 2. Inspect magnesium fittings. Replace any with cracks as prescribed, before further flight.  
 (FAA AD 89-05-02 refers)

- Compliance:**
1. Within next 100 hours TIS.
  2. At intervals not exceeding 100 hours TIS until replaced.

**Effective Date:** 16 June 1989

**DCA/B55/26 Wing Forward Spar Carry-Through Structure - Inspection**

**Applicability:** Models 95, B95, B95A, D95A, E95 aircraft, S/N TD-1 through TD-721.

Models 95-55, 95-A55, 95-B55 and 95-B55A aircraft, S/N TC-1 through TC-2456, except TC-350.

Models 95-C55, 95-C55A, D55, D55A, E55 and E55A aircraft, S/N TC-350 and TE-1 through TE-1201.

Models 95-B55B aircraft, S/N TF-1 through TF-70.

Models 56TC, A56TC aircraft, S/N TG-1 through TG-94.

Models 58, 58A aircraft, S/N TH-1 through TH-1475.

**Requirement:** To detect and correct fatigue cracks prior to wing failure, inspect wing forward spar carry-through structure per Beechcraft SB No. 2269 Rev.1. Rectify as prescribed.  
(FAA AD 90-08-14 refers)

**Compliance:** At 1500 hours TTIS or within next 100 hours TIS whichever is the later. Repeat thereafter at intervals prescribed in Beechcraft SB No. 2269.

**Effective Date:** 29 June 1990

**DCA/B55/27 Cancelled – DCA/B55/45 refers**

**Effective Date:** 8 January 2010

**DCA/B55/28 Engine Mount - Inspection**

**Applicability:** Models 95-C55, 95-C55A, D55, D55A, E55, and E55A aircraft, S/N TC-350 and S/N TE-1 through TE-1201.

Models 58 and 58A aircraft, S/N TH-1 through TH-1610.

**Requirement:** To prevent severe engine vibration and possible separation of the engine from the aircraft caused by cracked engine mounts, inspect each engine mount per Beechcraft SB 2362, rev. 1.

If a crack is found rectify per the SB before further flight.

(FAA AD 91-15-20 refers)

**Compliance:** At 600 hours TTIS or within next 100 hours TIS, whichever is the later and thereafter at intervals not exceeding 100 hours TIS. The repetitive inspection may be terminated on an engine mount that has been repaired and reinforced with Beech Kit 58-9007-1S or if a P/N 96-910010-67 engine mount has been installed.

**Effective Date:** 27 September 1991

**DCA/B55/29 Elevator Trim Tab Actuator - Colour Coding**

- Applicability:** Model 95-B55, 95-B55A aircraft, S/N TC-371, TC-502 through TC-2456  
Model 58, 58A aircraft, S/N TH-1 through TH-1388 and TH-1390 through TH-1395.
- Requirement:** To prevent aircraft loss of control because of interchanging the RH and LH elevator trim tab actuators, colour code the actuators per Beechcraft SB 2399.  
(FAA AD 91-17-01 refers)
- Compliance:** Next time the trim tab actuators are removed for any reason but no later than 28 February 1993.
- Effective Date:** 28 February 1992

**DCA/B55/30 Fuselage - Inspection and Modification**

- Applicability:** Models 58P and 58PA, with S/Ns listed in Beech SB 2630 or Raytheon SB 2691.
- Requirement:** To prevent structural cracking to the cabin caused by missing rivets, which, could cause decompression injuries to passengers, structural failure of the fuselage, and loss of the aircraft, accomplish the following:
1. Inspect the cabin window upper longeron (next to the upper aft splice) between the second and third right-hand (RH) cabin side windows for cracks and missing rivets per Beechcraft SB 2630.  
If cracks are found in the upper longeron, prior to further flight, repair the cracks per SB 2630.  
If rivets are found missing, prior to further flight, install the rivets per SB 2630.
  2. Inspect the RH lower longeron between the two doublers adjacent to the lower aft side of the RH second cabin window for cracks per PART I of Raytheon SB 2691, Rev 1.  
If cracks are found in the RH lower longeron, prior to further flight, repair and reinforce the cracks per PART II of SB 2691, Rev 1.  
If no cracks are found in the RH lower longeron, prior to further flight, reinforce the longeron per PART III of Raytheon Mandatory SB 2691 Rev 1.  
(FAA AD 97-09-09 refers)
- Compliance:** Within next 100 hours TIS.
- Effective Date:** 4 July 1997

**DCA/B55/31 Interior Door Handles - Inspection**

- Applicability:** Models 95-55, 95-A55, 95-B55, 95C-55, D55, E55, 56TC, A56TC, 58, 58TC, 95, B95, B95A, D95A, and E95 aircraft.
- Requirement:** To prevent unintentional opening of the cabin side door and the utility door from the interior of the aircraft, accomplish the following:
- Check the cabin side door handle and the utility door handle from the interior of the aircraft for proper locking (rotating the door handle clockwise without depressing the lock release button) per Raytheon SB 2693.
- If the door handle opens the door when rotated without depressing the handle's lock release button, prior to further flight, repair per SB 2693.



If the door handle is locked and will only unlock by depressing the handle door lock release button, then no further action is necessary.

(FAA AD 97-14-15 refers)

**Compliance:** Within next 50 hours TIS.

**Effective Date:** 29 August 1997

**DCA/B55/32 Severe Icing Conditions - Flight Manual Revision**

**Applicability:** Models E55, E55A, 58, 58A, 58P, 58PA, 58TC, and 58TCA aircraft.

**Requirement:** To minimise the potential hazards associated with operating the aircraft in severe icing conditions (by providing more clearly defined procedures and limitations associated with such conditions), incorporate the following into the Aircraft Flight Manual (AFM):-

**1. Limitations Section of the Aircraft Flight Manual**

“WARNING

Severe icing may result from environmental conditions outside of those for which the aircraft is certificated. Flight in freezing rain, freezing drizzle, or mixed icing conditions (supercooled liquid water and ice crystals) may result in ice build-up on protected surfaces exceeding the capability of the ice protection system, or may result in ice forming aft of the protected surfaces. This ice may not be shed using the ice protection systems, and may seriously degrade the performance and controllability of the aircraft.

- During flight, severe icing conditions that exceed those for which the aircraft is certificated shall be determined by the following visual cues. If one or more of these visual cues exists, immediately request priority handling from Air Traffic Control to facilitate a route or an altitude change to exit the icing conditions.
- Unusually extensive ice accumulation on the airframe and windshield in areas not normally observed to collect ice.
- Accumulation of ice on the upper surface of the wing aft of the protected area.
- Accumulation of ice on the engine nacelles and propeller spinners farther aft than normally observed.
- Since the autopilot, when installed and operating, may mask tactile cues that indicate adverse changes in handling characteristics, use of the autopilot is prohibited when any of the visual cues specified above exist, or when unusual lateral trim requirements or autopilot trim warnings are encountered while the aircraft is in icing conditions.
- All wing icing inspection lights must be operative prior to flight into known or forecast icing conditions at night. This supersedes any relief provided by the Master Minimum Equipment List (MMEL).”

**2. Normal Procedures Section of the Aircraft Flight Manual**

“THE FOLLOWING WEATHER CONDITIONS MAY BE CONDUCIVE TO SEVERE IN-FLIGHT ICING:

- Visible rain at temperatures below 0 degrees Celsius ambient air temperature.
- Droplets that splash or splatter on impact at temperatures below 0 degrees Celsius ambient air temperature.

**PROCEDURES FOR EXITING THE SEVERE ICING ENVIRONMENT:**

These procedures are applicable to all flight phases from takeoff to landing. Monitor the ambient air temperature. While severe icing may form at temperatures as cold as -18 degrees Celsius, increased vigilance is warranted at temperatures around freezing with visible moisture present. If the visual cues specified in the Limitations Section of the AFM for identifying severe icing conditions are observed, accomplish the following:

- Immediately request priority handling from Air Traffic Control to facilitate a route or an altitude change to exit the severe icing conditions in order to avoid extended exposure to flight conditions more severe than those for which the aircraft has been certificated.
- Avoid abrupt and excessive manoeuvring that may exacerbate control difficulties.
- Do not engage the autopilot.
- If the autopilot is engaged, hold the control wheel firmly and disengage the autopilot.
- If an unusual roll response or uncommanded roll control movement is observed, reduce the angle-of-attack.
- Do not extend flaps when holding in icing conditions. Operation with flaps extended can result in a reduced wing angle-of-attack, with the possibility of ice forming on the upper surface further aft on the wing than normal, possibly aft of the protected area.
- If the flaps are extended, do not retract them until the airframe is clear of ice.
- Report these weather conditions to Air Traffic Control.”

*Note: This may be accomplished by inserting a copy of this AD in the AFM or by incorporating a manufacturer's flight manual revision that contains the wording per this AD.*

**3. Flight Crew Notification**

Operators must ensure that flight crew are aware of the flight manual revision.

(FAA AD 98-04-24 refers)

**Compliance:** By 10 May 1998

**Effective Date:** 10 April 1998

**DCA/B55/33**                    **Cancelled – Purpose Fulfilled**

**DCA/B55/34**                    **Flight Controls – Inspection for Interference**

**Applicability:** Model 58 and 58A aircraft, S/N TH-1806 through TH-1840, TH-1842 through TH-1854, TH-1856, TH-1860 through TH-1867, and TH-1870.

**Requirement:** To prevent any components or wiring from interfering with the flight control mechanism caused by inadequate clearance, which could result in loss of aileron and/or elevator control, accomplish the following:-

Inspect for interference or inadequate clearance between the flight control mechanism and any component located forward of the instrument panel. Perform this inspection per Raytheon Mandatory SB 27-3232.

If interference or inadequate clearance is found, prior to further flight, secure all components clear of the flight control mechanism as specified in SB 27-3232.

(FAA AD 99-09-15 refers)

**Compliance:** Within next 25 hours TIS.

**Effective Date:** 4 June 1999

**DCA/B55/35 Elevator Skin Assemblies - Replacement**

**Applicability:** Models 95-A55 aircraft, S/N TC-191 through TC-349, TC-351 through TC-370, TC-372 through TC-501  
 Model 95-B55 aircraft, S/N TC-371, TC-502 through TC-2406  
 Model 95-C55 aircraft, S/N TC-350, TE-1 through TE-49, and TE-51 through TE-451  
 Model D55 aircraft, S/N TE-452 through TE-767  
 Model E55 S/N aircraft, S/N TE-768 through TE-1201  
 Model 56TC aircraft, S/N TG-2 through TG-83  
 Model A56TC aircraft, S/N TG-84 through TG-94  
 Model 58 aircraft, S/N TH-1 through TH-1930  
 Model 58P aircraft, S/N TJ-3 through TJ-435 and TJ-437 through TJ-443  
 Model 58TC aircraft, S/N TK-1 through TK-150  
 Model 95-B55B (T42-A) aircraft, S/N TF-1 through TF-70

**Requirement:** To detect and correct potential elevator skin separation, a reduction in static strength capability and possible aircraft flutter with consequent loss of control of the aircraft, accomplish the following:-

Check the maintenance records per Raytheon MSB 27-3396 Rev 1, to determine whether one of the affected elevator skin assemblies was installed after 31 December 1998.

If one of the elevator skin assemblies (particular P/Ns referenced in MSB 27-3396 Rev 1) is not installed, or was installed prior to 1 January 1999, then the replacement requirement of this AD does not apply.

Replace any elevator skin assembly (particular P/Ns referenced in MSB 27-3396) that Raytheon shipped anytime from 1 January 1999 through 31 December 1999. Accomplish this replacement per MSB 27-3396.

Installation Prohibition: Elevator skin assembly (particular P/Ns referenced in MSB 27-3396 Rev 1) that Raytheon shipped anytime from 1 January 1999 through 31 December 1999, may not be installed on any aircraft.

(FAA AD 2000-18-02 refers)

**Compliance:** By 28 October 2000

**Effective Date:** 28 September 2000

**DCA/B55/36 Rudder Interconnect Tube - Inspection**

**Applicability:** Model 58 aircraft, S/N TH-1389 and TH-1396 through TH-1885.

**Requirement:** To prevent wear in the pilot/copilot pedal interconnect tube, which could result in loss of rudder control, accomplish the following:-

Inspect the rudder bellcrank interconnect tube for damage and ensure the floorboard panel screws are 3/4 inch or less in length. Screws that are longer than 3/4 inch in length can damage parts installed immediately below the floorboards. Accomplish this inspection and any replacement or repair, before further flight after the inspection per Raytheon Mandatory SB 27-3013, and the Baron Model 58 Shop Manual.

If no damage is found to the rudder bellcrank interconnect tube, discard any self-tapping coarse thread screw installed in the flanges that is longer than 3/4 inch.

If damage is found to the rudder bellcrank interconnect tube, and the damage has not worn into the aluminum interconnect tube, refinish the interconnect tube and discard any self-tapping coarse thread screw installed in the flanges that is longer than 3/4 inch.

If damage is found to the rudder bellcrank interconnect tube, and the damage has worn into the aluminum interconnect tube, replace the interconnect tube and discard any self-tapping coarse thread screw installed in the flanges that is longer than 3/4 inch.

Plug the floorboard screw hole.

(FAA AD 2000-22-18 refers)

**Compliance:** Inspect by 30 June 2001

**Effective Date:** 21 December 2000

#### **DCA/B55/37A Fuselage Assembly - Inspection**

**Applicability:** Model 58 and 58A aircraft, S/N TH-1 through TH-1811, and TH-1813 through TH-1897.

**Requirement:** To prevent critical structural failure of the aircraft due to missing rivets in the right hand fuselage panel assembly area above the right wing and below the cabin door threshold, accomplish the following:

Inspect for up to 9 missing rivets between fuselage station (FS) 83.00 and F.S. 91.00 at water line (WL) 90.3 per Raytheon Mandatory SB 53-3341, Revision 1, and the applicable Maintenance Manual.

If rivets are found missing, prior to further flight, install these rivets per SB 53-3341, Revision 1, and the applicable Maintenance Manual.

(FAA AD 2003-01-01 refers)

**Compliance:** Within next 100 hours TIS unless already accomplished.

**Effective Date:** DCA/B55/37A - 27 March 2003  
DCA/B55/37 - 22 February 2001

#### **DCA/B55/38 Rudder Control System - Inspection**

**Applicability:** Model 58 aircraft, S/N TH-1576 through TH-1838.

**Requirement:** To correct any misrouted rudder control cables and consequent guard pin wear or fraying of the cables and to prevent possible loss of rudder control, accomplish the following:-

Inspect rudder control system per Raytheon Mandatory SB 27-3265, and the applicable aircraft Maintenance Manual or Shop Manual.

Before further flight, replace any worn or damaged guard pins and pulley brackets.

Check the aircraft log book to determine if a misrouted control cable was detected during earlier maintenance and the misrouting was corrected. If a misrouting has been recorded or found during this inspection, before further flight install replacement rudder control cables in accordance with the following:-

(i) Apply corrosion preventive compounds, as necessary, to provide corrosion protection.

(ii) Install rudder control cables.

(iii) Adjust rudder control cables to correct tension and adjust control surface travel.

(iv) Perform an operational checkout of the flight control system to ensure proper operation of installed rudder control cables, pulley brackets, guard pins and attaching hardware. Accomplish this per SB 27-3265, and the applicable aircraft Maintenance Manual or Shop Manual.

(FAA AD 2000-24-04 refers)

**Compliance:** Within next 50 hours TIS.

**Effective Date:** 22 February 2001

#### **DCA/B55/39 Flap Flex Shafts - Inspection**

**Applicability:** Group 1: Model 58 aircraft, S/Ns TH-1936 through TH-1988 & TH-1990 through TH-1996

Group 2: Model 96-55, 95-A55, 95-B5 5, 95-B55A, 95-B55B(T-42A), 95-C55, 95-C55A D55, D55A, E55, and E55A aircraft, all S/Ns, and Model 56TC, A56TC aircraft, all S/Ns and Model 58, 58A, 58P, 58PA, 58TC and 58TCA aircraft, all S/Ns except those in Group 1.  
Model 95, B95,B95A, D95A and E95 aircraft, all S/Ns.

**Requirement:** To prevent failure of the flap flex shafts that may result in an asymmetric flap condition, accomplish the following:-

Group 1: Inspect the left (P/N 12527Y-63.31), and right (P/N 12163Y-63.31 or 12163Y-1), flap flex shaft assemblies to determine the date of manufacture on the identification label. If the date of manufacture is between Jan 2000 and Apr 2001 replace the flex shaft with an item manufactured outside this date range, before further flight.

Group 2: Check the aircraft logbook to determine whether the left or right hand flap flex shaft assemblies have been replaced since 01 March 2000. If the flex shafts have been changed after this time inspect/replace as for Group 1 aircraft. If the flex shaft assemblies have not been changed since 01 March 2000, no further action is required.

(FAA AD 2001-23-10 refers)

**Compliance:** Within next 25 hours TIS.

**Effective Date:** 20 December 2001

#### **DCA/B55/40 Electroluminescent Panel Retaining Screw – Inspection**

<b>Applicability:</b>	<u>Model</u>	<u>S/N</u>
	E55 and E55A	TE-768 through TE-1201.
	A56TC	TG-84 through TG-94.
	58 and 58A	TH-1 through TH-1388 and TH-1390 through TH-1395.
	58P and 58PA	TJ-3 through TJ-435 and TJ-437 through TJ-443.
	58TC and 58TCA	TK-1 through TK-146 and TK-148 through TK-150.

**Requirement:** To prevent damage to the rotating beacon circuit breaker switch or any other switch in the same location, because of an incorrect length electroluminescent panel retaining screw, accomplish the following.

Inspect the Instrument Subpanel electroluminescent panel for the installation of a rotating beacon circuit breaker switch or any other switch directly above the lower electroluminescent panel retaining screw.

If a blanking plug is installed above the lower electroluminescent panel retaining screw, ensure that the correct length screw is installed. The correct length is 0.28 to 0.31 inches. If the screw is not the correct length, install P/N MS35214-24 or equivalent. The incorrect length screw could result in failure of the circuit breaker and lead to smoke and/or fire in the cockpit

If a rotating beacon circuit breaker switch or any other switch is installed, inspect the switch for damage, per Raytheon SB 33-3452. Replace any damaged switch and replace the electroluminescent panel retaining screw if it is not 0.28 to 0.31 inches in length with a P/N MS35214-24 screw or equivalent.

(FAA AD 2002-11-07 refers)

**Compliance:** Inspect within 100 hours TIS.

**Effective Date:** 25 July 2002

#### **DCA/B55/41 Propeller Unfeathering Accumulators – Inspection and Replacement**

**Applicability:** Model 58 and G58 aircraft, S/N TH-2097 through to TH-2150 fitted with optional propeller unfeathering accumulators.

**Requirement:** To prevent engine oil loss due to the possibility of chafing of the left propeller accumulator oil tube assembly which may result in fire or smoke in the engine compartment, inability to unfeather the propeller, engine damage, or loss of engine power, accomplish the following:

Inspect the left propeller accumulator oil tube assembly for chafing per Raytheon Aircraft Company Mandatory Service Bulletin (MSB) No. SB 61-3806.

If any chafing is found, replace the propeller accumulator oil tube assembly per MSB No. SB 61-3806 before further flight.

Reposition and secure the left manifold pressure hose with clamps, and ensure there is sufficient clearance between all tubes, hoses, electrical wires, parts, components, and structure per MSB No. SB 61-3806.

(FAA AD 2007-06-07 refers)

**Compliance:** Within the next 25 hours TIS for aircraft not inspected per Raytheon Safety Communiqué No. 271

Within the next 50 hours TIS for aircraft inspected per Raytheon Safety Communiqué No. 271.

**Effective Date:** 25 October 2007

#### **DCA/B55/42 MLG Retract Mechanism – Modification and Lubrication**

**Applicability:** Model 58 aircraft, S/N TH-1 through to TH-174

**Requirement:** To prevent a wheels up landing due to the possibility of seizure of the MLG uplock rollers, accomplish the following:

1. Inspect the MLG uplock rollers, per Beechcraft Service Instruction No. 0448-211.

Replace non greasible uplock rollers with the greasible type and install hollow zerk-ended mounting bolts on the uplock rollers, per Beechcraft Service Instruction (SI) No. 0448-211, before further flight.

**Note:** Non greasible uplock rollers have a solid inner race. The greasible type have a drilled and grooved inner race.

2. Lubricate the uplock mechanism per SI No. 0448-211.

(FAA AD 2007-08-08 refers)

**Compliance:**

1. Within the next 300 hours TIS.
2. Within the next 300 hours TIS and thereafter at intervals not to exceed 100 hours TIS.

**Effective Date:** 25 October 2007

#### **DCA/B55/43 Airframe Structure – Life Limitation & AFM Amendment**

**Applicability:** Model 58P and 58TC aircraft, S/N TJ-177, TJ-178, TJ-180, TJ-211, TJ-213, TJ-247, TJ-284, TJ-285, TJ-289, TJ-290, TJ-314, TJ-322, TJ-367, TJ-368, TJ-370, TJ-371, TJ-425, TJ-426, TJ-433, TJ-442 and TK-33

**Note 1:** These aircraft were used as lead aircraft by the United States Forest Service for fire fighting missions.

**Requirement:** To prevent structural failure of the airframe which includes the wings, fuselage, empennage and associated structure, accomplish the following:

1. Amend the Pilot Operating Handbook (POH) & Aircraft Flight Manual (AFM) by inserting Raytheon supplement P/N 102-590000-67, issued January 2005 into the limitations section of the POH/AFM P/N 102-590000-41 or 106-590000-5, as applicable.

**Note 2:** The POH/AFM supplement limits the structural fatigue life of the wings, fuselage, empennage and associated structure to 4500 hours TIS.

**Note 3:** The AFM amendment may be performed and certified under the provision in Part 43 Appendix A.1 (7) by the holder of a current pilot licence, if that person is rated on the aircraft, appropriately trained and authorised (Part 43, Subpart B refers), and the amendment is recorded and certified as required by Part 43.

2. Remove the aircraft from service.

(FAA AD 2007-21-02 refers)

**Compliance:** 1. & 2. At 4500 hours TTIS or before further flight, whichever occurs later.

**Effective Date:** 25 October 2007

#### **DCA/B55/44 Circuit Breaker Toggle Switches – Replacement**

**Applicability:** Model 95-B55 aircraft, S/N TC-1913, TC-1936 through to TC-2456, and Model D55 aircraft, S/N TE-452 through to TE-767, and Model E55 aircraft, S/N TE-768 through to TE-1201, and Model A56TC aircraft, S/N TG-84 through to TG-94, and Model 58 aircraft, S/N TH-1 through to TH-2124, and Model 58P aircraft, S/N TJ-3 through to TJ-497, and Model 58TC aircraft, S/N TK-1 through to TK-151, and

Model G58 aircraft, S/N TH-2126, TH-2127, TH-2131 through to TH-2134, TH-2136, TH-2137, TH-2139 through to TH-2141 and TH-2143 through to TH-2150, and Fitted with circuit breaker toggle switches P/N 35-380132-1 through to P/N 35-380132-53.

- Requirement:** To prevent failure of affected circuit breaker toggle switches due to possible overheating which could result in smoke in the cockpit and the inability to turn the switch off, accomplish the following:
1. Replace all affected circuit breaker toggle switches with an improved circuit breaker toggle switch P/N 35-380132-61 through to P/N 35-380132-113 as applicable, per the instructions in Hawker Beechcraft SB 24-3807, issued May 2007, and Raytheon Aircraft Company SB 24-3735, issued August 2005.
  2. An affected circuit breaker shall not be fitted to any aircraft.
- (FAA AD 2008-13-17 refers)
- Compliance:**
1. By 28 August 2009.
  2. From 28 August 2008.
- Effective Date:** 28 August 2008

**DCA/B55/45      Shoulder Harness Guide Retaining Washer – Inspection and Replacement**

- Applicability:** Model 58 and 58A aircraft, S/N TH-733 through to TH-1609  
Model 58P and 58PA aircraft, S/N TJ-3 through to TJ-497  
Model 58TC and 58TCA aircraft, S/N TK-1 through to TK-151  
Model 95-B55 and 95-B55A aircraft, S/N TC-1947 through to TC-2456
- Note:** This AD supersedes DCA/B55/27 to revise the applicability with no change to the requirement. No action required if already in compliance with DCA/B55/27.
- Requirement:** To prevent the pilot and copilot shoulder harnesses detaching from the airframe due to the possible installation of an incorrect washer which could result in a shoulder harness malfunction, accomplish the following:
- Inspect the washers on the "D" ring of the pilot and copilot shoulder harnesses for the correct material, inner and outer diameter, and thickness per the instructions in Beechcraft MSB No. 2394 dated December 1990.
- If an incorrect washer is found fitted, replace with washer P/N 100951X060YA per MSB No. 2394 before further flight.
- (FAA AD 2009-25-01 refers)
- Compliance:** Within the next 100 hours TIS unless previously accomplished.
- Effective Date:** 8 January 2010



**DCA/B55/46A Elevator Control System – Inspection and Replacement**

**Applicability:** Model 58 and 95-55 series aircraft, all S/N fitted with a forward elevator control cable configuration per figure 1 of this AD.

**Note 1:** No further AD action required for those aircraft already in compliance with DCA/B55/46. This AD revised to clarify the applicability and revise the requirement. Figure 1 introduced to provide additional information to determine AD applicability. The repetitive inspections and the requirement to replace forward elevator control cable assemblies which have been in service for more than 15 years has been removed from this AD with the publication of manufacturer Instructions for Continuing Airworthiness (ICA).

**Requirement:** To prevent loss of elevator control which could result in loss of aircraft control, accomplish the following:

1. Replace the forward elevator cable assembly, or

Inspect the forward elevator control cable assembly for wear, broken wires and corrosion. If any defects are found, replace the forward elevator control cable assembly before further flight.

2. Cable assemblies or parts removed from service per the requirements of this AD may not be installed on any aircraft.

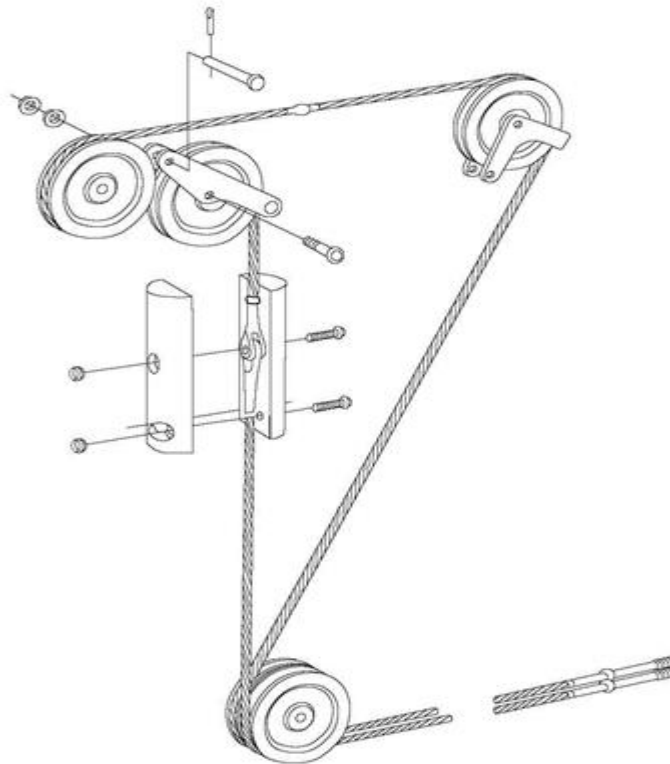

Figure 1 - Forward Elevator Control Cable - Adapted from the Beechcraft IPC.

**Note 2:** Compliance with chapter 7, section 8, paragraph 7-149(d) of FAA AC 43-13-1B, or the manufacturer maintenance instructions are an acceptable means of compliance for the inspections mandated by this AD.

(CASA AD AD/BEECH 55/98 refers)

**Compliance:** 1. For aircraft that have not had the forward elevator cable assembly replaced or inspected at the last maintenance inspection:

Before further flight after 19 January 2012 (the effective date of DCA/B55/46).

For aircraft that have had the forward elevator control cable assembly replaced or inspected at the last maintenance inspection:

At the next scheduled maintenance inspection.

2. From 19 January 2012 (the effective date of DCA/B55/46).

**Effective Date:** DCA/B55/46 - 19 January 2012  
DCA/B55/46A - 29 March 2012

**DCA/B55/47      Airspeed Indicator Markings – Inspection and Rework**

**Applicability:** Model 95-C55, D55, E55, 58 and 58A aircraft, all S/N embodied with STC SA1762SO.

**Note:** STC SA1762SO introduces new Continental IO-550 engines, new Hartzell 4-bladed propellers and the addition of winglets. This STC is sometimes referred to as the "Foxstar modification".

**Requirement:** To prevent an unsafe condition, accomplish the inspections and corrective actions specified in FAA AD 2011-27-04.

(FAA AD 2011-27-04 refers)

**Compliance:** Within the next 10 hours TIS.

**Effective Date:** 20 January 2012

**DCA/B55/48      Fuel Hose Clamps – Inspection and Replacement**

**Applicability:** Model 58 aircraft, S/N TH-1931 through to TH-2124

Model G58 aircraft, S/N TH-2125 through to TH-2281, TH-2283 and TH-2284

**Requirement:** To correct the installation of oversized clamps on fuel vapour return and/or fuel vent lines in the outboard sections of the left and right wings, accomplish the following:  
Inspect the fuel hose clamps for oversized or deformed clamps per the instructions in Hawker Beechcraft MSB No. SB 28-4039 revision 1, dated October 2011.

If any oversized or deformed clamps are found, replace affected clamps per the instructions in MSB No. SB 28-4039 before further flight.

**Note:** If a scheduled inspection becomes due before the compliance time of this AD, the CAA recommends compliance with this AD at that time.

(FAA AD 2012-10-02 refers)

**Compliance:** Within the next 50 hours TIS, or by 28 December 2012 whichever occurs sooner.

**Effective Date:** 28 June 2012

The State of Design ADs listed below are available directly from the National Airworthiness Authority (NAA) websites. Links to NAA websites are available on the CAA website at <https://www.aviation.govt.nz/aircraft/airworthiness/airworthiness-directives/links-to-state-of-design-airworthiness-directives/> If additional NZ ADs need to be issued when an unsafe condition is found to exist in an aircraft or aeronautical product in NZ, they will be added to the list below.

**2012-21-05            Strobe System Wiring – Replacement**

**Effective Date:** 27 November 2012

**\* 2013-16-01           Elevator Balance Weights – Inspection**

**Effective Date:** 24 September 2013